

**Receive the education you need to succeed in Agile Projects**  
**Achieve the prestigious Education-Based Certifications**

# **Certified Agile Software Test Professional (CASTP)**

**CASTP – Practitioner Level**  
**CASTP – Master Level**

For additional information:  
**(877) Get-IIST**  
**[www.iist.org](http://www.iist.org)**



**International Institute for Software Testing**  
*Promoting Disciplined Software Testing Practices*



## Background

Agile approaches and methodologies have been widely adopted by many software organizations. Although organizations are still going through a learning process from one project to another to adjust their agile practices to what works and avoid what does not work, the number of software projects adopting agile is increasing every day. Test professionals' involvement in agile project remains challenged because of the different nature of the agile approach. Although we can see some test professionals succeeding in agile projects, many others continue to struggle to succeed. It is evident that testing in agile projects is very different from testing in other projects that use approaches, including but not limited to the waterfall model. The testing community needs to adapt very quickly to this new technology. To that end, the International Institute for Software Testing (IIST), the leading organization in Education-Based Certifications, recognized the need for an educational program that is based on a solid Body of Knowledge that leads to a professional Certification. IIST relied on its experience and position as the leader in Education-Based Certifications and assumed the responsibility to develop the **Agile Testing Body of Knowledge (ATBOK)**. Through the unique efforts of its highly regarded Advisory Board, since 1999, IIST has developed the following Bodies of Knowledge and offered Education-Based Certifications based on these BOKs.

- The Software Test Professionals Body of Knowledge (STPBOK)
- The Software Test Management Body of Knowledge (TMBOK)
- The Software Test Automation Body of Knowledge (STABO)
- The Software Quality Management Body of Knowledge (SQMBOK)
- The Software Process Improvement Body of Knowledge (SPIBOK), developed by IIST's sister organization, the International Institute for Software Process.

## The Certified Agile Software Test Professional (CASTP) Credential

### Objectives of the CASTP Certification

- To help test professionals develop communication and team dynamics skills required for agile projects
- To help test professionals perform testing activities in an expedited manner while maintaining a structured process
- To help test professionals adapt to the fast pace, incremental, and iterative culture of agile projects
- To help test professionals become very effective in agile projects

### Who Should Pursue Certification?

- All individuals who have been performing testing activities and wish to gain skills to help them work on agile projects
- Test leads and test managers who intend to manage the testing effort in agile projects
- Developers interested in conducting more effective testing in agile projects



## Where Does the CASTP Fit Within the IIST Education-Based Certifications Program?

The following chart shows where the CASTP certification fits within the comprehensive education-based certification program at IIST.

[Type a quote from the document or the summary of an interesting point. You can position the text box anywhere in the document. Use the Drawing Tools tab to change the formatting of the pull quote text box.]

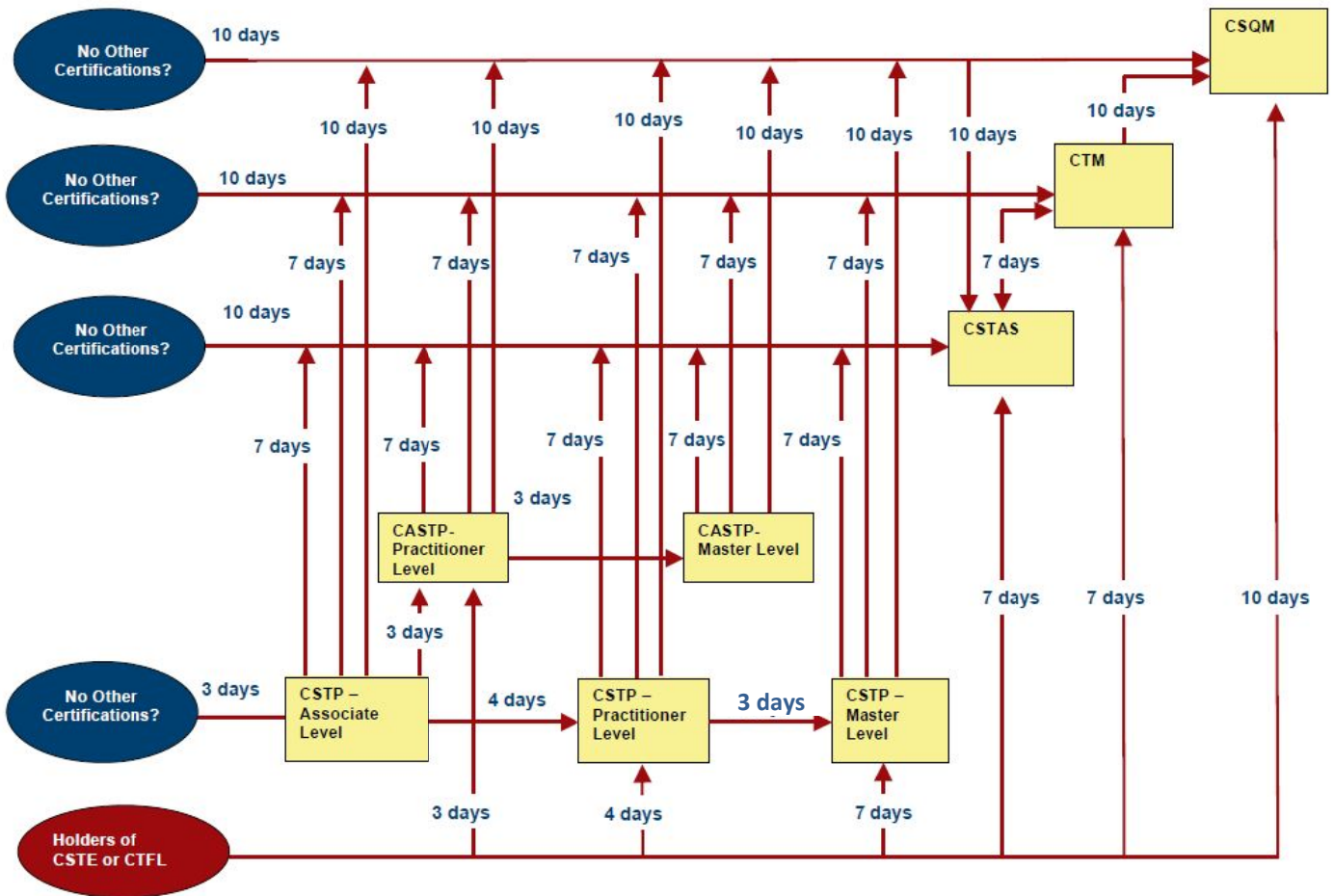

<b>CSTP:</b> Certified Software Test Professional	<b>CTM:</b> Certified test Manager
<b>CASTP:</b> Certified Agile Software Test Professional	<b>CSQM:</b> Certified Software Quality Manager
<b>CSTAS:</b> Certified Software Test Automation Specialist	



## The CASTP Certification Requirements

The CASTP has two levels, the **CASTP – Practitioner Level** and the **CASTP - Master Level**. These are detailed below for each level

# The Certified Agile Software Test Professional Practitioner Level (CASTP – P)

### **Pre-requisites**

Before pursuing the CASTP – P level, a candidate must satisfy the following two pre-requisites:

1. Achieving the Certified Software Test Professional – Associate level or equivalent
2. Must have worked for at least one year in a software testing-related job. This requirement shall be met by means of a letter of support signed by the candidate's supervisor describing the candidate's specific role and responsibilities over a period of one year or more.

### **Formal Education Requirements:**

Three days of training to cover the following areas of the Agile Testing Body of Knowledge (ATBOB):

1. Agile Development Methodologies (CASTP #1)
2. Agile Requirement Exploration and Requirement Management (CASTP #2)
3. Agile Test Design and Test Execution (CASTP #3)

### **Written Exam:**

Candidates are required to complete a written exam for each course and pass with a level of performance no less than 80%. For courses conducted by IIST, a candidate is allowed to retake the exam for a second time without having to attend the course again. There is a \$100 fee for retakes. If 80% performance is not achieved on a second attempt, the candidate must retake the course or take another course covering the same ATBOK area if available.

### **CASTP Practitioner Level Re-Certification Requirements**

The CASTP - Practitioner Level Certification will expire 3 years after it is granted. All CSTP – P Certified participants must complete the recertification requirements before that time. The recertification requirements are three days of training to cover any topic in software testing within three years. Days of training may be used to satisfy the requirements of a higher level certification, including the CASTP – Master Level. All training requires attending an exam in each course and achieving 80% performance.



## The Certified Agile Software Test Professional Master Level (CASTP – M)

### ***Pre-requisites***

Before pursuing the CASTP – M level, a candidate must satisfy the following two pre-requisites:

1. Achieving the Certified Agile Software Test Professional – Practitioner
2. Must have worked for a total of two years in a software testing-related job. This requirement shall be met by means of a letter of support signed by the candidate's supervisor describing the candidate's specific role and responsibilities over a period of one year or more.

### ***Formal Education Requirements:***

Three days of training to cover the following areas of the Agile Testing Body of Knowledge (ATBOK):

1. Agile Test Management (CASTP #4)
2. Agile Test Automation (CASTP #5)
3. Collaboration and Team Dynamics Tools and Techniques (CASTP #6)

### ***Written Exam:***

Candidates are required to complete a written exam for each course and pass with a level of performance no less than 80%. For courses conducted by IIST, a candidate is allowed to retake the exam for a second time without having to attend the course again. There is a \$100 fee for retakes. If 80% performance is not achieved on a second attempt, the candidate must retake the course or take another course covering the same ATBOK area if available.



# The Agile Testing Body of Knowledge (ATBOK)

The ATBOK consists of six areas. These are detailed below.

## 1. Agile Development Methodologies

- 1.1. The values, principles and philosophies that underpin Agility
- 1.2. The Agile Manifesto
- 1.3. Contrasting Agility with other software development methods
- 1.4. Agile vs. traditional incremental approaches
- 1.5. Agile Methods
- 1.6. Roles and responsibilities in the agile team
- 1.7. The team approach in agile
- 1.8. The iterative and incremental lifecycle
- 1.9. Continuous Integration
- 1.10. Progressive requirements elaboration
- 1.11. Iterative planning and adaptation
- 1.12. Incremental product delivery
- 1.13. Coaching self-directed teams
- 1.14. Agile project monitoring
- 1.15. Agile and process improvement

## 2. Agile Requirement Exploration and Requirement Management

- 2.1. The role of requirements in software
- 2.2. Requirements vs. Scenarios
- 2.3. Functional vs. non-functional requirements
- 2.4. Releases and Iteration planning
- 2.5. Product and Iteration backlogs
- 2.6. Burndown Charts
- 2.7. Managing requirement changes
- 2.8. User Stories and Acceptance Criteria
- 2.9. Use Cases

## 3. Agile Test Design and Test Execution

- 3.1. Acceptance Criteria
- 3.2. Exploratory Testing
- 3.3. Ad hoc Testing
- 3.4. Structured testing
- 3.5. Designing Tests based on User Stories Acceptance Criteria
- 3.6. Designing tests based on Use Cases
- 3.7. Writing scripts
- 3.8. Manual test execution
- 3.9. Automated test execution
- 3.10. Bug reporting
- 3.11. Ad hoc testing
- 3.12. Defect Management
- 3.13. Regression testing

## 4. Agile Test Management

- 4.1. Agile testing quadrants
- 4.2. Types of Agile testing
  - 4.2.1. Development Level Testing
    - 4.2.1.1. Unit and component Testing
    - 4.2.1.2. Test Driven Development (TDD)
  - 4.2.2. Feature Level Testing
    - 4.2.2.1. Story Testing
    - 4.2.2.2. Scenario Testing
    - 4.2.2.3. Use Case Testing



- 4.2.2.4. Behavior-driven Development (BDD)
- 4.2.3. System Level Testing
- 4.2.4. User Acceptance Testing (UAT)
- 4.3. Test Strategies and Planning
  - 4.3.1. Release level (Theme) planning
  - 4.3.2. Iteration Kickoff level planning
  - 4.3.3. Light weight test plan
- 4.4. Test Planning
- 4.5. Scheduling
- 4.6. Resources
- 4.7. Risk Management
- 4.8. Effort estimation
  - 4.8.1. Story estimation
  - 4.8.2. Feature estimation
- 4.9. Test metrics

## 5. Agile Test Automation

- 5.1. The importance of automation in Agile projects
- 5.2. The Test Automation Pyramid
- 5.3. What we should automate and what we should not
- 5.4. How to automate when GUI is not ready
- 5.5. How to automate when no baseline test cases are available
- 5.6. Continuous integration
- 5.7. Automating unit and component tests
- 5.8. Test-Driven Development
- 5.9. Automating feature testing
- 5.10. Automating system and integration testing
- 5.11. Automating regression testing
- 5.12. Automating non-functional testing
- 5.13. Load and performance testing
- 5.14. Lightweight Automation Test Plan
- 5.15. Automation frameworks
  - 5.15.1. Unit and Component testing frameworks
  - 5.15.2. Feature and Story testing frameworks

## 6. Collaboration and Team Dynamics Tools and Techniques

- 6.1. Collaboration procedures
- 6.2. Tester/Developer collaboration
- 6.3. Tester/Customer collaboration
- 6.4. Collaboration and communication between distributed teams
- 6.5. Collaborative reviews
  - 6.5.1. Story and feature reviews
  - 6.5.2. Test Reviews
  - 6.5.3. Use Case Reviews
- 6.6. Collaboration tools

### References:

1. Agile Testing: A Practical Guide for Testers and Agile Teams  
By: Lisa Crispin; Janet Gregory, Publisher: Addison-Wesley Professional
2. User Stories Applied, By: Mike Cohn, Publisher Pearson education, Inc.
3. Exploratory Software Testing by James A. Whittaker, Addison-Wesley

# Achieve the Prestigious Designations:

Develop your Career Through  
Education-Based Certifications

**CSTP-A**  
**Certified**

Certified Software Test Professional  
Associate Level

**CSTAS**  
**Certified**

Certified Software Test Automation  
Specialist

**CSTP-P**  
**Certified**

Certified Software Test Professional  
Practitioner Level

**CASTP-P**  
**Certified**

Certified Agile Software Test  
Professional - Practitioner Level

**CSTP-M**  
**Certified**

Certified Software Test Professional  
Master Level

**CASTP-M**  
**Certified**

Certified Agile Software Test  
Professional - Master Level

**CTM**  
**Certified**

Certified Test Manager

**CSQM**  
**Certified**

Certified Software Quality Manager

## The only education-based certifications for software test and quality professionals



International Institute for Software Testing

*Promoting Disciplined Software Testing Practices*

[www.iist.org](http://www.iist.org)

636 Mendelssohn Avenue North  
Golden Valley, MN 55427, USA